

DTL

The new
synchronous linear motors
Designer`s dream!
We bring dynamics to linear motion!



High thrust combined with

- Compact design
- Little moving mass
- High efficiency
- No attraction force



DTL 85

Synchronous linear motors
for standard servo-amplifiers
with 3-phase windings
bearingless design with water-cooling
The motion drive from BOB
for short strokes

Motor Type	Thrust			Stroke (mm)	Maximum permitted intermediate circuit voltage $U_{bc} = 700 \text{ V}$ ($U_{eff} = 500 \text{ V}$)	Mass		Dimensions	
	F_0 20°C (N)	F_c 130°C (N)	F_{max} (N)			Primary unit (kg)	Second. unit (kg)	L (mm)	A (mm)
DTL-85 / 102- 3stw - 1 - S	141	118	217	27,5		1,3	0,8	116,0	79,5
DTL-85 / 103- 3stw - 1 - S				55,0				143,5	
DTL-85 / 104- 3stw - 1 - S				82,5				171,0	
DTL-85 / 105- 3stw - 1 - S				110,0				198,5	
DTL-85 / 106- 3stw - 1 - S				137,5				226,0	
DTL-85 / 203- 3stw - 1 - S	279	235	434	27,5		1,8	1,2	143,5	107
DTL-85 / 204- 3stw - 1 - S				55,0				171,0	
DTL-85 / 205- 3stw - 1 - S				82,5				198,5	
DTL-85 / 206- 3stw - 1 - S				110,0				226,0	
DTL-85 / 207- 3stw - 1 - S				137,5				253,5	
DTL-85 / 304- 3stw - 1 - S	421	352	651	27,5		2,2	1,6	171,0	134,5
DTL-85 / 305- 3stw - 1 - S				55,0				198,5	
DTL-85 / 306- 3stw - 1 - S				82,5				226,0	
DTL-85 / 307- 3stw - 1 - S				110,0				253,5	
DTL-85 / 308- 3stw - 1 - S				137,5				281,0	
DTL-85 / 405- 3stw - 1 - S	561	468	868	27,5		2,6	2,0	198,5	162
DTL-85 / 406- 3stw - 1 - S				55,0				226,0	
DTL-85 / 407- 3stw - 1 - S				82,5				253,5	
DTL-85 / 408- 3stw - 1 - S				110,0				281,0	
DTL-85 / 409- 3stw - 1 - S				137,5				308,5	
DTL-85 / 506- 3stw - 1 - S	700	585	1086	27,5		3,1	2,4	226,0	189,5
DTL-85 / 507- 3stw - 1 - S				55,0				253,5	
DTL-85 / 508- 3stw - 1 - S				82,5				281,0	
DTL-85 / 509- 3stw - 1 - S				110,0				308,5	
DTL-85 / 510- 3stw - 1 - S				137,5				336,0	
DTL-85 / 607- 3stw - 1 - S	839	701	1303	27,5	3,5	2,8	253,5	217	
DTL-85 / 608- 3stw - 1 - S				55,0			281,0		
DTL-85 / 609- 3stw - 1 - S				82,5			308,5		
DTL-85 / 610- 3stw - 1 - S				110,0			336,0		
DTL-85 / 708- 3stw - 1 - S				978			817		1520
DTL-85 / 709- 3stw - 1 - S	55,0	308,5							
DTL-85 / 710- 3stw - 1 - S	82,5	336,0							

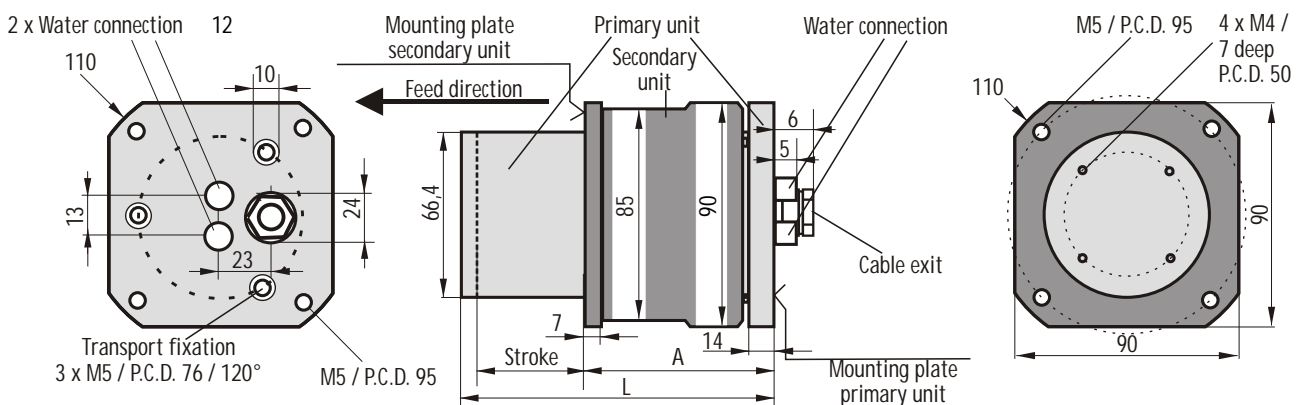

We serve a wide range of linear and servo motors. Please ask for additional, detailed information
Own design and production All products Made in Germany



BOB synchronous linear motor

Type DTL description and order-key-code

Series DTL

compare tubular, three-phase, synchronous linear motors with ironcore windings and integrated water-cooling.

These motors consist of two bearingless, interconnecting cylinders.

The guidance of the motor is guaranteed by the bearing of the load.

Use:

Typical applications are z-axes of drilling- and milling-machines etc. as well as x-y-tables with short strokes.

Advantages:

These motors are remarkable due to their excellent ratio of power to weight. By means of the bearingless design the overstressing of driving-shaft and bearing is avoided.

The shown data

are valid for water-cooling at a winding-temperature of 130°C and an ambient temperature of 20°C. (Cooling water temperature 20°C and temperature increase of cooling water 10°K)

Order-key-code

DTL	FFF	/	SPP	-	3stw	-	x	-	m
-----	-----	---	-----	---	------	---	---	---	---

Type _____

Code for motor flange _____

Code for length of secondary unit _____

Code for length of primary unit _____

3-phase _____

Code for connection _____

S = Star-connection

Temperature sensor _____

N = NTC 130°C

P = PTC 130°C

K = KTY 84-130

Code for winding _____

Determines maximum speed

Code for magnet type _____

1 = Standard

Modification _____

S = Standard

C = Modification as requested by customer
(with Id.-No.-data-sheet)

Length of of connection-cable = 0,6 m (Standard)

Other length on request (must be ordered seperately in every order)

BOB Synchronous linear motor

Water-cooling

DTL 85 / 1.. - 3StZ - 1 - S

Max. permitted input voltage: 700 V_{DC} (≅ 500 V_{eff})

	Symbol	Unit	..0203040506 ..
Cont. force (Cu:130°C + v>0,01m/s)	F _c	N	144	142	141	141	140
Cont. force (@ v<0,01m/s ± s<20mm)	F _s	N	120	119	118	118	117
Maximum force (max. 1 sec)	F _{max}	N	217	217	217	217	217
Max. permitted loss cooled	P _{v,max}	W	236	346	455	564	674
Max. permitted loss uncooled	P _{v,max,o.k.}	W	68,4	93,6	118,9	144,2	169,4
Thermal resistance at V/t _{min}	R _{th}	K/W	0,44	0,30	0,23	0,19	0,16
Motor constant	K _m	N/W ^{1/2}	9,4	7,6	6,6	5,9	5,4
Force constant	K _f	N/A	39,2	39,2	39,2	39,2	39,2
Back EMF constant	K _e	Vs/m	22,6	22,6	22,6	22,6	22,6
elektr. Zeitkonstante	t _e	ms	0,76	0,53	0,41	0,35	0,30
Currant (Cu: 20°C)	I ₀	A	3,67	3,63	3,60	3,59	3,58
Continuous current (Cu: 130°C)	I _c	A	3,07	3,03	3,01	3,00	2,99
Maximum current	I _{max}	A	7,9	7,9	7,9	7,9	7,9
Demagnetising current	I _d	A	20	20	20	20	20
DC-resistance Ph/Ph (Cu: 20°C)	R		11,68	17,53	23,37	29,21	35,05
Inductance Ph/Ph	L	mH	8,84	9,25	9,67	10,09	10,51
Pole pitch	p	mm	13,75	13,75	13,75	13,75	13,75
Max. permitted pressure	p	MPa	0,3	0,3	0,3	0,3	0,3
Cooling water flow min.	V/t _{min}	l/min	0,3	0,4	0,5	0,7	0,8
Cooling water temperature max.	T	°C	20	20	20	20	20
Cooling water temp. increase max.	T	K	10	10	10	10	10
Mass secondary unit	m _l	kg	0,8	0,8	0,8	0,8	0,8
Total mass	m	kg	2,4	2,8	3,3	3,7	4,2
Maximum acceleration *	a _{max}	m/s ²	239	239	239	239	239
Maximum speed *	v _{max}	m/s	2,57	3,63	4,44	5,13	5,74
Responding working voltage *	U _{eff}	V	164	240	311	378	443

Electrical figures apply for sinusoidal commutation and are r.m.s. values or refer to r.m.s. values respectively. Data shown with * are theoretical maximum values.

Connection	Connection	Code
Cable : 4 G 1,5 + (2 x 0,5) (shielded) Ø 12,1 mm	Phase U	U BK
	Phase V	V V BK
	Phase W	WWW BK
	PE	GNYE
	MT +	+ BK
	MT -	- WH
MT : NTC / 130 °C (t = N) PTC / 130 °C (t = P) KTY 84 - 130 (t = K)	Shield	WH or "SHIELD"

Minimum bending radius for flexing: 10 x cable diameter
 static: 7,5 x cable diameter

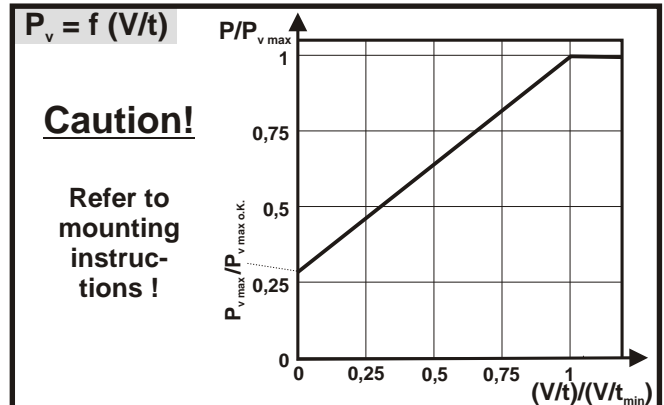

Dimensions

shown with secondary unit in B-side end-position

2 water-hose connectors (A + B) 12
 110
 10
 13
 24
 23
 transport fixation 3 x M5x12 / P.C.D. 76/120°
 M5 / P.C.D. 95

mounting plate secondary unit (A-side)
 feed direction
 66,4
 85
 90
 7
 Stroke
 L
 A
 14
 8
 5
 water-hose connectors d_a = 6
 cable exit
 mounting plate primary unit (B-side)

M5 / P.C.D. 95 4 x M4 / 7 deep P.C.D. 50
 110
 90
 Air gap : 0,5 mm
 perm. eccentricity : < 0,1 mm

Typ	Stroke	L	Delivery state	Operation state
DTL 85 / 102-...-S	27,5	116	79,5	82
DTL 85 / 103-...-S	55	143,5	79,5	82
DTL 85 / 104-...-S	82,5	171	79,5	82
DTL 85 / 105-...-S	110	198,5	79,5	82
DTL 85 / 106-...-S	137,5	226	79,5	82

Performance data are tolerated +/-10%. Measurements in mm.

The rights are reserved to make modification in the general sense of technical progress without previous notice.

BOB Synchronous linear motor

Water-cooling

DTL 85 / 2.. - 3StY - 1 - S

Max. permitted input voltage: 700 V_{DC} (≅ 500 V_{eff})

	Symbol	Unit	..0304050607 ..
Cont. force (Cu:130°C + v>0,01m/s)	F _c	N	285	283	282	281	280
Cont. force (@ v<0,01m/s ± s<20mm)	F _s	N	238	236	235	235	234
Maximum force (max. 1 sec)	F _{max}	N	434	434	434	434	434
Max. permitted loss cooled	P _{v,max}	W	346	456	565	675	784
Max. permitted loss uncooled	P _{v,max,o.k.}	W	94,2	119,7	145,1	170,5	196,0
Thermal resistance at V/t _{min}	R _{th}	K/W	0,30	0,23	0,19	0,16	0,13
Motor constant	K _m	N/W ^{1/2}	15,3	13,2	11,8	10,8	10,0
Force constant	K _t	N/A	39,0	39,0	39,0	39,0	39,0
Back EMF constant	K _e	Vs/m	22,5	22,5	22,5	22,5	22,5
elektr. Zeitkonstante	t _e	ms	1,99	1,53	1,25	1,07	0,94
Currant (Cu: 20°C)	I ₀	A	7,30	7,25	7,22	7,21	7,19
Continuous current (Cu: 130°C)	I _c	A	6,10	6,06	6,04	6,02	6,01
Maximum current	I _{max}	A	15,9	15,9	15,9	15,9	15,9
Demagnetising current	I _b	A	40	40	40	40	40
DC-resistance Ph/Ph (Cu: 20°C)	R		4,33	5,78	7,22	8,67	10,11
Inductance Ph/Ph	L	mH	8,62	8,83	9,04	9,25	9,46
Pole pitch	p	mm	13,75	13,75	13,75	13,75	13,75
Max. permitted pressure	p	MPa	0,3	0,3	0,3	0,3	0,3
Cooling water flow min.	V/t _{min}	l/min	0,4	0,5	0,7	0,8	0,9
Cooling water temperature max.	T	°C	20	20	20	20	20
Cooling water temp. increase max.	T	K	10	10	10	10	10
Mass secondary unit	m _l	kg	1,3	1,3	1,3	1,3	1,3
Total mass	m	kg	3,3	3,7	4,1	4,6	5,0
Maximum acceleration *	a _{max}	m/s ²	323	323	323	323	323
Maximum speed *	v _{max}	m/s	2,98	4,22	5,17	5,96	6,67
Responding working voltage *	U _{eff}	V	171	239	296	348	397

Electrical figures apply for sinusoidal commutation and are r.m.s. values or refer to r.m.s. values respectively. Data shown with * are theoretical maximum values.

Connection	Connection	Code
Cable : 4 G 1,5 + (2 x 0,5) (shielded) Ø 12,1 mm MT : NTC / 130 °C (t = N) PTC / 130 °C (t = P) KTY 84 - 130 (t = K)	Phase U	U BK
	Phase V	V V BK
	Phase W	WWW BK
	PE	GNYE
	MT +	+ BK
	MT -	- WH
	Shield	WH or "SHIELD"

Minimum bending radius for flexing: 10 x cable diameter static: 7,5 x cable diameter

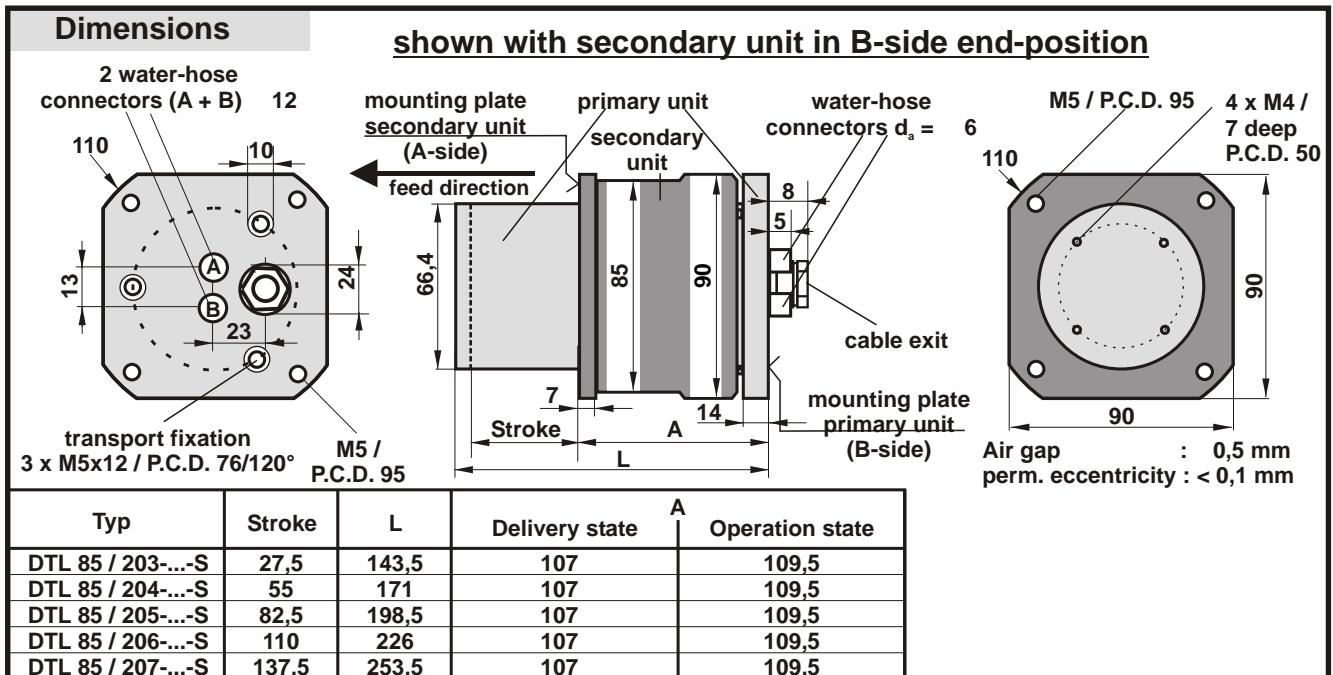
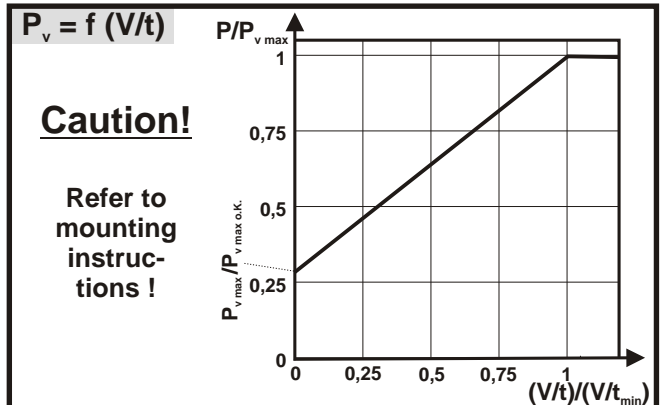

Performance data are tolerated +/-10%. Measurements in mm.

The rights are reserved to make modification in the general sense of technical progress without previous notice.

BOB Synchronous linear motor

Water-cooling

DTL 85 / 4.. - 3StX - 1 - S

Max. permitted input voltage: 700 V_{DC} (≅ 500 V_{eff})

	Symbol	Unit	..0506070809 ..
Cont. force (Cu:130°C + v>0,01m/s)	F _c	N	563	562	561	560	559
Cont. force (@ v<0,01m/s ± s<20mm)	F _s	N	471	469	468	468	467
Maximum force (max. 1 sec)	F _{max}	N	868	868	868	868	868
Max. permitted loss cooled	P _{v,max}	W	565	674	784	893	1002
Max. permitted loss uncooled	P _{v,max,o.k.}	W	144,5	169,9	195,2	220,5	245,8
Thermal resistance at V/t _{min}	R _{th}	K/W	0,19	0,16	0,13	0,12	0,10
Motor constant	K _m	N/W ^{1/2}	23,7	21,6	20,0	18,7	17,7
Force constant	K _f	N/A	54,0	54,0	54,0	54,0	54,0
Back EMF constant	K _e	Vs/m	31,2	31,2	31,2	31,2	31,2
elektr. Zeitkonstante	t _e	ms	2,52	2,13	1,86	1,65	1,49
Currant (Cu: 20°C)	I ₀	A	10,43	10,40	10,38	10,37	10,36
Continuous current (Cu: 130°C)	I _c	A	8,72	8,69	8,68	8,66	8,65
Maximum current	I _{max}	A	23,0	23,0	23,0	23,0	23,0
Demagnetising current	I _b	A	60	60	60	60	60
DC-resistance Ph/Ph (Cu: 20°C)	R		3,46	4,15	4,84	5,54	6,23
Inductance Ph/Ph	L	mH	8,72	8,86	9,01	9,15	9,30
Pole pitch	p	mm	13,75	13,75	13,75	13,75	13,75
Max. permitted pressure	p	MPa	0,3	0,3	0,3	0,3	0,3
Cooling water flow min.	V/t _{min}	l/min	0,7	0,8	0,9	1,0	1,1
Cooling water temperature max.	T	°C	20	20	20	20	20
Cooling water temp. increase max.	T	K	10	10	10	10	10
Mass secondary unit	m _l	kg	2,1	2,1	2,1	2,1	2,1
Total mass	m	kg	5,0	5,4	5,8	6,3	6,7
Maximum acceleration *	a _{max}	m/s ²	392	392	392	392	392
Maximum speed *	v _{max}	m/s	3,28	4,64	5,69	6,57	7,34
Responding working voltage *	U _{eff}	V	246	339	415	482	543

Electrical figures apply for sinusoidal commutation and are r.m.s. values or refer to r.m.s. values respectively. Data shown with * are theoretical maximum values.

Connection	Connection	Code
Cable : 4 G 1,5 + (2 x 0,5) (shielded) Ø 12,1 mm	Phase U	U BK
	Phase V	V V BK
	Phase W	WWW BK
	PE	GNYE
	MT +	+ BK
	MT -	- WH
MT : NTC / 130 °C (t = N) PTC / 130 °C (t = P) KTY 84 - 130 (t = K)	Shield	WH or "SHIELD"

Minimum bending radius for flexing: 10 x cable diameter
static: 7,5 x cable diameter

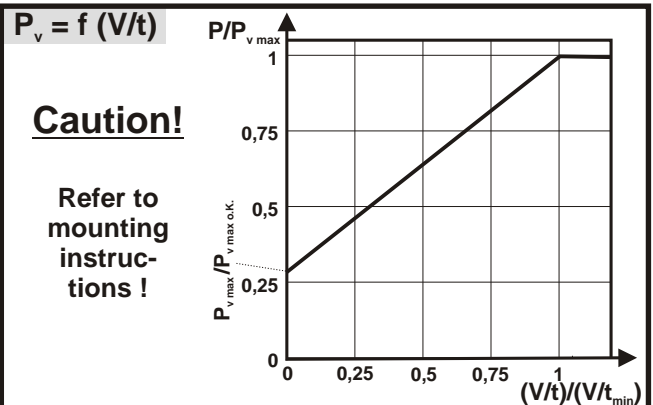

Dimensions

shown with secondary unit in B-side end-position

2 water-hose connectors (A + B) 12

mounting plate secondary unit (A-side)

primary unit

secondary unit

water-hose connectors d_a = 6

M5 / P.C.D. 95 4 x M4 / 7 deep P.C.D. 50

transport fixation 3 x M5x12 / P.C.D. 76/120°

M5 / P.C.D. 95

Stroke

L

A

Operation state

Typ	Stroke	L	Delivery state	Operation state
DTL 85 / 405-...-S	27,5	198,5	162	164,5
DTL 85 / 406-...-S	55	226	162	164,5
DTL 85 / 407-...-S	82,5	253,5	162	164,5
DTL 85 / 408-...-S	110	281	162	164,5
DTL 85 / 409-...-S	137,5	308,5	162	164,5

Air gap : 0,5 mm
perm. eccentricity : < 0,1 mm

Performance data are tolerated +/-10%. Measurements in mm.

The rights are reserved to make modification in the general sense of technical progress without previous notice.

BOB Synchronous linear motor

Water-cooling

DTL 85 / 5.. - 3StX - 1 - S

Max. permitted input voltage: 700 V_{DC} (≅ 500 V_{eff})

	Symbol	Unit	..0607080910 ..
Cont. force (Cu:130°C + v>0,01m/s)	F _c	N	702	701	700	699	698
Cont. force (@ v<0,01m/s ± s<20mm)	F _s	N	587	586	585	584	584
Maximum force (max. 1 sec)	F _{max}	N	1086	1086	1086	1086	1086
Max. permitted loss cooled	P _{v,max}	W	674	784	893	1002	1112
Max. permitted loss uncooled	P _{v,max,o.k.}	W	169,9	195,2	220,5	245,8	271,2
Thermal resistance at V/t _{min}	R _{th}	K/W	0,16	0,13	0,12	0,10	0,09
Motor constant	K _m	N/W ^{1/2}	27,0	25,0	23,4	22,1	20,9
Force constant	K _t	N/A	67,5	67,5	67,5	67,5	67,5
Back EMF constant	K _e	Vs/m	39,0	39,0	39,0	39,0	39,0
elektr. Zeitkonstante	t _e	ms	2,13	1,86	1,65	1,49	1,36
Currant (Cu: 20°C)	I ₀	A	10,40	10,38	10,37	10,36	10,35
Continuous current (Cu: 130°C)	I _c	A	8,69	8,68	8,66	8,65	8,65
Maximum current	I _{max}	A	23,0	23,0	23,0	23,0	23,0
Demagnetising current	I _b	A	60	60	60	60	60
DC-resistance Ph/Ph (Cu: 20°C)	R		4,15	4,84	5,54	6,23	6,92
Inductance Ph/Ph	L	mH	8,86	9,01	9,15	9,30	9,44
Pole pitch	p	mm	13,75	13,75	13,75	13,75	13,75
Max. permitted pressure	p	MPa	0,3	0,3	0,3	0,3	0,3
Cooling water flow min.	V/t _{min}	l/min	0,8	0,9	1,0	1,1	1,3
Cooling water temperature max.	T	°C	20	20	20	20	20
Cooling water temp. increase max.	T	K	10	10	10	10	10
Mass secondary unit	m _l	kg	2,5	2,5	2,5	2,5	2,5
Total mass	m	kg	5,8	6,3	6,7	7,1	7,6
Maximum acceleration *	a _{max}	m/s ²	410	410	410	410	410
Maximum speed *	v _{max}	m/s	3,36	4,75	5,81	6,71	7,50
Responding working voltage *	U _{eff}	V	289	394	480	556	624

Electrical figures apply for sinusoidal commutation and are r.m.s. values or refer to r.m.s. values respectively. Data shown with * are theoretical maximum values.

Connection	Connection	Code
Cable : 4 G 1,5 + (2 x 0,5) (shielded) Ø 12,1 mm	Phase U	U BK
	Phase V	V V BK
	Phase W	WWW BK
	PE	GNYE
	MT +	+ BK
	MT -	- WH
MT : NTC / 130 °C (t = N) PTC / 130 °C (t = P) KTY 84 - 130 (t = K)	Shield	WH or "SHIELD"

Minimum bending radius for flexing: 10 x cable diameter static: 7,5 x cable diameter

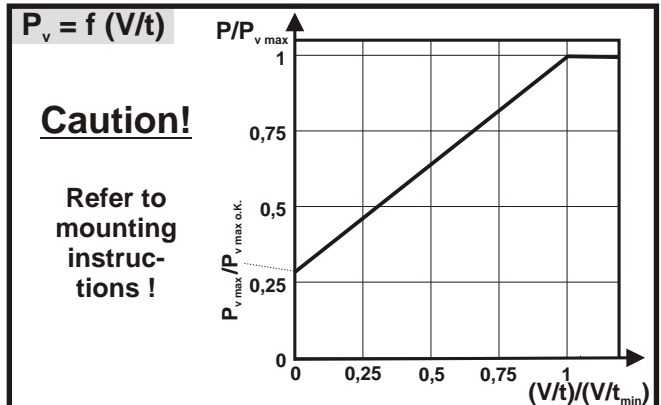

Dimensions

shown with secondary unit in B-side end-position

2 water-hose connectors (A + B) 12
 110
 10
 24
 13
 23
 transport fixation 3 x M5x12 / P.C.D. 76/120°
 M5 / P.C.D. 95

mounting plate secondary unit (A-side)
 feed direction
 66,4
 85
 90
 7
 Stroke
 L
 A
 14
 8
 5
 water-hose connectors d_a = 6
 cable exit
 mounting plate primary unit (B-side)

M5 / P.C.D. 95 4 x M4 / 7 deep P.C.D. 50
 110
 90
 Air gap : 0,5 mm
 perm. eccentricity : < 0,1 mm

Typ	Stroke	L	Delivery state	Operation state
DTL 85 / 506-...-S	27,5	226	189,5	192
DTL 85 / 507-...-S	55	253,5	189,5	192
DTL 85 / 508-...-S	82,5	281	189,5	192
DTL 85 / 509-...-S	110	308,5	189,5	192
DTL 85 / 510-...-S	137,5	336	189,5	192

Performance data are tolerated +/-10%. Measurements in mm.

The rights are reserved to make modification in the general sense of technical progress without previous notice.

BOB Synchronous linear motor

Water-cooling

DTL 85 / 6.. - 3StX - 1 - S

Max. permitted input voltage: 700 V_{DC} (≅ 500 V_{eff})

	Symbol	Unit	..07080910 ..
Cont. force (Cu:130°C + v>0,01m/s)	F _c	N	841	840	839	838
Cont. force (@ v<0,01m/s ± s<20mm)	F _s	N	703	702	701	700
Maximum force (max. 1 sec)	F _{max}	N	1303	1303	1303	1303
Max. permitted loss cooled	P _{v,max}	W	784	893	1002	1112
Max. permitted loss uncooled	P _{v,max,o.K.}	W	195,2	220,5	245,8	271,2
Thermal resistance at V/t _{min}	R _{th}	K/W	0,13	0,12	0,10	0,09
Motor constant	K _m	N/W ^{1/2}	30,0	28,1	26,5	25,1
Force constant	K _t	N/A	81,0	81,0	81,0	81,0
Back EMF constant	K _e	Vs/m	50,0	50,0	50,0	50,0
elektr. Zeitkonstante	t _e	ms	1,6	1,6	1,7	1,7
Currant (Cu: 20°C)	I ₀	A	10,38	10,37	10,36	10,35
Continuous current (Cu: 130°C)	I _c	A	8,68	8,66	8,65	8,65
Maximum current	I _{max}	A	23,0	23,0	23,0	23,0
Demagnetising current	I _b	A	60	60	60	60
DC-resistance Ph/Ph (Cu: 20°C)	R		4,9	5,8	6,5	7,3
Inductance Ph/Ph	L	mH	8,0	9,5	10,9	12,4
Pole pitch	p	mm	13,75	13,75	13,75	13,75
Max. permitted pressure	p	MPa	0,3	0,3	0,3	0,3
Cooling water flow min.	V/t _{min}	l/min	0,9	1,0	1,1	1,3
Cooling water temperature max.	T	°C	20	20	20	20
Cooling water temp. increase max.	T	K	10	10	10	10
Mass secondary unit	m ₁	kg	2,9	2,9	2,9	2,9
Total mass	m	kg	6,7	7,1	7,5	8,0
Maximum acceleration *	a _{max}	m/s ²	422	422	422	422
Maximum speed *	v _{max}	m/s	3,41	4,82	5,90	6,81
Responding working voltage *	U _{eff}	V	332	449	545	629

Electrical figures apply for sinusoidal commutation and are r.m.s. values or refer to r.m.s. values respectively. Data shown with * are theoretical maximum values.

Connection	Connection	Code
Cable : 4 G 1,5 + (2 x 0,5) (shielded) Ø 12,1 mm MT : NTC / 130 °C (t = N) PTC / 130 °C (t = P) KTY 84 - 130 (t = K)	Phase U	U BK
	Phase V	V V BK
	Phase W	WWW BK
	PE	GNYE
	MT +	+ BK
	MT -	- WH
	Shield	WH or "SHIELD"

Minimum bending radius for flexing: 10 x cable diameter static: 7,5 x cable diameter

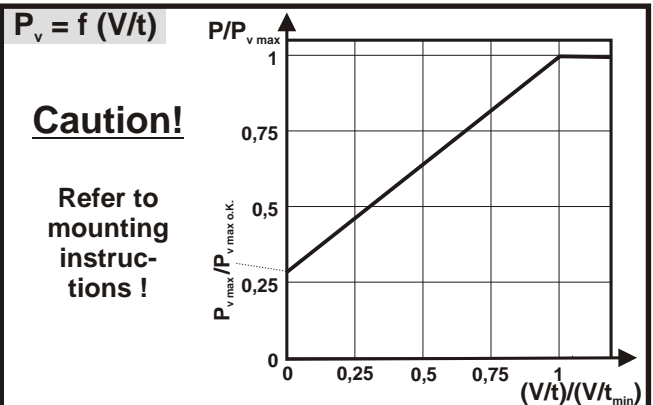

Dimensions

shown with secondary unit in B-side end-position

2 water-hose connectors (A + B) 12
 110
 10
 24
 13
 23
 transport fixation 3 x M5x12 / P.C.D. 76/120°
 M5 / P.C.D. 95

mounting plate secondary unit (A-side)
 feed direction
 66,4
 85
 90
 7
 Stroke
 L
 14
 8
 5
 water-hose connectors d_a = 6
 cable exit
 mounting plate primary unit (B-side)

M5 / P.C.D. 95
 4 x M4 / 7 deep P.C.D. 50
 110
 90
 90
 Air gap : 0,5 mm
 perm. eccentricity : < 0,1 mm

Typ	Stroke	L	Delivery state	Operation state
DTL 85 / 607-...-S	27,5	253,5	217	219,5
DTL 85 / 608-...-S	55	281	217	219,5
DTL 85 / 609-...-S	82,5	308,5	217	219,5
DTL 85 / 610-...-S	110	336	217	219,5

Performance data are tolerated +/-10%. Measurements in mm.

The rights are reserved to make modification in the general sense of technical progress without previous notice.

BOB Synchronous linear motor

Water-cooling

DTL 85 / 7.. - 3StX - 1 - S

Max. permitted input voltage: 700 V_{DC} (≅ 500 V_{eff})

	Symbol	Unit	..080910 ..
Cont. force (Cu:130°C + v>0,01m/s)	F _c	N	980	979	978
Cont. force (@ v<0,01m/s ± s<20mm)	F _s	N	819	818	817
Maximum force (max. 1 sec)	F _{max}	N	1520	1520	1520
Max. permitted loss cooled	P _{v,max}	W	893	1002	1112
Max. permitted loss uncooled	P _{v,max,o.k.}	W	220,5	245,8	271,2
Thermal resistance at V/t _{min}	R _{th}	K/W	0,12	0,10	0,09
Motor constant	K _m	N/W ^{1/2}	32,8	30,9	29,3
Force constant	K _f	N/A	94,5	94,5	94,5
Back EMF constant	K _e	Vs/m	54,6	54,6	54,6
elektr. Zeitkonstante	t _e	ms	1,65	1,49	1,36
Current (Cu: 20°C)	I ₀	A	10,37	10,36	10,35
Continuous current (Cu: 130°C)	I _c	A	8,66	8,65	8,65
Maximum current	I _{max}	A	23,0	23,0	23,0
Demagnetising current	I _b	A	60	60	60
DC-resistance Ph/Ph (Cu: 20°C)	R		5,54	6,23	6,92
Inductance Ph/Ph	L	mH	9,15	9,30	9,44
Pole pitch	p	mm	13,75	13,75	13,75
Max. permitted pressure	p	MPa	0,3	0,3	0,3
Cooling water flow min.	V/t _{min}	l/min	1,0	1,1	1,3
Cooling water temperature max.	T	°C	20	20	20
Cooling water temp. increase max.	T	K	10	10	10
Mass secondary unit	m _l	kg	3,3	3,3	3,3
Total mass	m	kg	7,5	8,0	8,4
Maximum acceleration *	a _{max}	m/s ²	431	431	431
Maximum speed *	v _{max}	m/s	3,44	4,87	5,97
Responding working voltage *	U _{eff}	V	375	505	609

Electrical figures apply for sinusoidal commutation and are r.m.s. values or refer to r.m.s. values respectively. Data shown with * are theoretical maximum values.

Connection	Connection	Code
Cable : 4 G 1,5 + (2 x 0,5) (shielded) Ø 12,1 mm MT : NTC / 130 °C (t = N) PTC / 130 °C (t = P) KTY 84 - 130 (t = K)	Phase U	U BK
	Phase V	V V BK
	Phase W	WWW BK
	PE	GNYE
	MT +	+ BK
	MT -	- WH
	Shield	WH or "SHIELD"

Minimum bending radius for flexing: 10 x cable diameter
 static: 7,5 x cable diameter

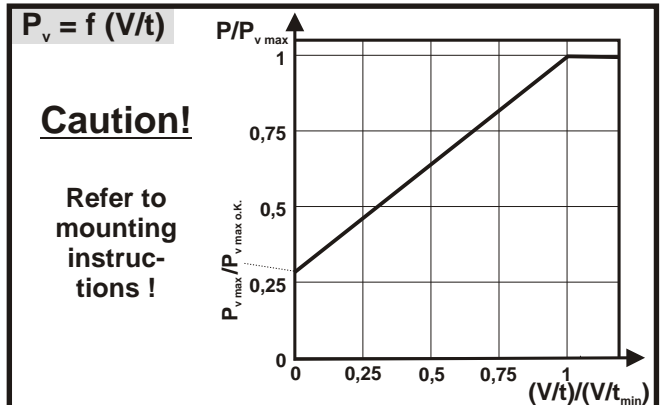

Dimensions

shown with secondary unit in B-side end-position

Typ	Stroke	L	Delivery state	Operation state
DTL 85 / 708-...-S	27,5	281	244,5	247
DTL 85 / 709-...-S	55	308,5	244,5	247
DTL 85 / 710-...-S	82,5	336	244,5	247

Performance data are tolerated +/-10%. Measurements in mm.

The rights are reserved to make modification in the general sense of technical progress without previous notice.